

PAGE®



ST 40A Systems

Operation & Maintenance Manual

PACE Incorporated retains the right to make changes to specifications contained herein at any time, without notice.

Contact your local authorized PACE Distributor or PACE Incorporated to obtain the latest specifications.

The following are registered trademarks and/or servicemarks of PACE Incorporated, Laurel Maryland U.S.A. and may only be used to identify genuine PACE products or services:

AdapTip, Arm-Evac, Cir-Kit, ComForm I, ConductTweez, CRAFT, Dual Path, Flo-D-Sodr, FuseSet, HandiPik, HotSpot, LapFlo, MBT, Micro Portable, MicroChine, MiniChine, Mini-Wave, PACE, Pacenter, Ped-A-Vac, PETS, Pik-Vac, PRC, PRINT, Pro-Evac, Redi-Rak, ResistTweez, SensaTemp, SMR, Snap-Vac, Sodr-Pen, Sodr-X-Tractor, SR-3, SR-4, ST, StripTweez, SwaPlater, ThermoBand, Thermo-Drive, ThermoJet, ThermoPart, ThermoPik, ThermoTweez, Tip-Evac, VisiFilter.

The following are trademarks and/or servicemarks of PACE Incorporated, Laurel Maryland U.S.A. and may only be used to identify genuine PACE products or services:

Auto Off, Cubby-Vac, Datastore, Dust Evac, EKO, Fume Scoop, Heat Wave, Lab Evac, Pacelink, PaceNet, Pik & Paste, Pik-Tip, Prep-Set, Pulse Plate, Sodrtek, ThermoBond, ThermoFlo, TinSpin, Toolnet, TweezPik, Uni-Frame, V-A-N, Ventur-Evac.



Since 1958, PACE Incorporated has provided advanced technology training in all aspects of hand soldering, rework and repair.

Additional copies of this manual or other PACE literature may be obtained from:

PACE Incorporated
Sales Administration
9893 Brewers Court
Laurel MD 20723-1990

(301) 490 - 9860
(301) 498 - 3252 Fax

MANUAL NUMBER 5050-0361

REV. D

SYSTEM QUICK START

The ST 40A system is very easy to operate and can be quickly set up for use in standard soldering operations.

To begin operation of your new system quickly, perform the "Set-Up" and "Quick Start - Basic Operation" procedures detailed on pages 6-11 & 16-17 of this manual. A shaded title bar on each of these pages highlight their location.

For any questions regarding this Operation & Maintenance Manual, contact your local authorized PACE distributor or contact PACE directly at:

Telephone (301) 490-9860, Fax (301) 604-8782

**PACE Incorporated
9893 Brewers Court
Laurel MD 20723-1990**

Table of Contents

<i>TITLE</i>	<i>PAGE</i>
General Information	4
Introduction	4
Specifications	4
Parts Identification	5
Safety	6
Set-Up	6
System	6
SP Tip & Tool Stand	7
Handpiece Connection	8
Air Hose Routing	8
System Power Up	8
Heater Burn In	9
PaceLink	11
Handpiece Tips	12
Tip Selection & Use	12
Tip Installation	14
Quick Start - Basic Operation	16
Introduction	16
Quick Start Procedure	16
Operation	18
Definitions	18
Auto Tip Temperature Compensation	19
Password	19
Basic Operation	20
Digital Readout Operation	20
Power Up	22
Panel Controls	22
Temperature Setback	27
Activation	27
Operation	27
Exiting Temperature Setback	28
Auto Off Safety System	28
Operation	28
Exiting Auto Off	28
Factory Settings	29

Table of Contents

<i>TITLE</i>	<i>PAGE</i>
Set-Up Mode	30
Introduction	30
Entering Set-Up Mode	30
Operation	31
Password	31
°F/°C Digital Readout	32
Temperature Limits	32
Temperature Setback	33
Auto Off Safety System	34
Digital Readout Accuracy	34
Corrective Maintenance	35
Digital Readout Message Codes	35
Power Source	36
Handpieces	37
Heater Replacement	38
Replacement Parts	40
SP-1A/SP-2A Handpieces	40
Accessory Items	41
Manual Improvement & Comment Form	42

<i>TABLE</i>	<i>PAGE</i>
Table I Single Point Tips	13
Table II Factory Settings	29
Table III Digital Readout Message Codes	35
Table IV Power Source Corrective Maintenance	36
Table V Heater Assembly Checkout Procedures	37
Table VI SP-1A/SP-2A Parts	40
Table VII Accessory Items	41

General Information

Introduction

Thank you for purchasing the PACE model ST 40A Digital Soldering System. This manual will provide you with the information necessary to properly set up, operate and maintain the ST 40A system.

The ST 40A system utilizes the model PPS 25A power source which incorporates a highly responsive SensaTemp (closed loop) control system providing up to 80 Watts of total power to a single output channel. The standard SP-2A Sodr-Pen (uses 3/16" shank tips) provides high capacity heating necessary to perform thru-hole soldering and SMT component removal/replacement operations. The optional SP-1A Sodr-Pen (uses 1/8" shank tips) incorporates a smaller profile heater assembly to access solder joints on very densely populated assemblies.

Other available PACE SensaTemp handpieces may be used with the ST 40A system to perform a wide variety of advanced surface mount & thru-hole component removal/replacement operations. These include:

TT-65 ThermoTweez Handpiece	TJ-70 Mini ThermoJet Handpiece*
TP-65 ThermoPik Handpiece*	SX-70 Sodr-X-Tractor Handpiece*

* These handpieces require an air source. Any of these handpieces can be used if the system power source is connected to a PACE ST 60 system (via PaceLink Receptacle). Alternatively, a Ped-A-Vac III Foot Pedal may be purchased and connected to a 60-90 p.s.i. air supply to provide a vacuum source for these Air Handpieces.

Specifications

System Power Source Power Requirements:

The system power sources are available in either the 115 VAC, 230 VAC or 100 VAC version as listed below. The 230 VAC version system bears the CE Conformity Marking which assures the user that it conforms to all the requirements of council directive EMC 89/336/EEC. Exposure to radio frequency interference in the range of 27-400 MHz may cause 230 VAC system resets or loss of handpiece temperature; the system functions normally once interference is removed.

PPS 25A (ST 40A system)	Operates on 97-127 VAC, 50/60Hz 90 Watts maximum at 115 VAC, 60Hz
PPS 25AE (ST 40AE system)	Version operates on 197-264 VAC 50/60Hz 80 Watts maximum at 230 VAC, 50Hz
PPS 25AJ (ST 40AJ system)	Version operates on 90-115 VAC 50/60Hz 80 Watts maximum at 100 VAC, 50/60Hz

Temperature Specifications:

Tip Temperature Range: 38°C to 482°C (100°F to 900°F) nominal.

Temperature Stability: $\pm 1.1^{\circ}\text{C}$ ($\pm 2^{\circ}\text{F}$) at idle from set tip temp.

NOTE - Actual minimum and maximum Operating Tip Temperatures may vary depending on Handpiece, Tip selection and application.

EOS/ESD Specifications:

The specifications shown below apply except on "Soft Ground Systems" which have a 1 meg ohm current limiting resistance and a label placed on the power source front panel referring to EN 100015-1.

Tip-To-Ground Resistance: Less than 5 ohms.

AC Leakage: Less than 2 Millivolts RMS from 50Hz to 500Hz.

Parts Identification

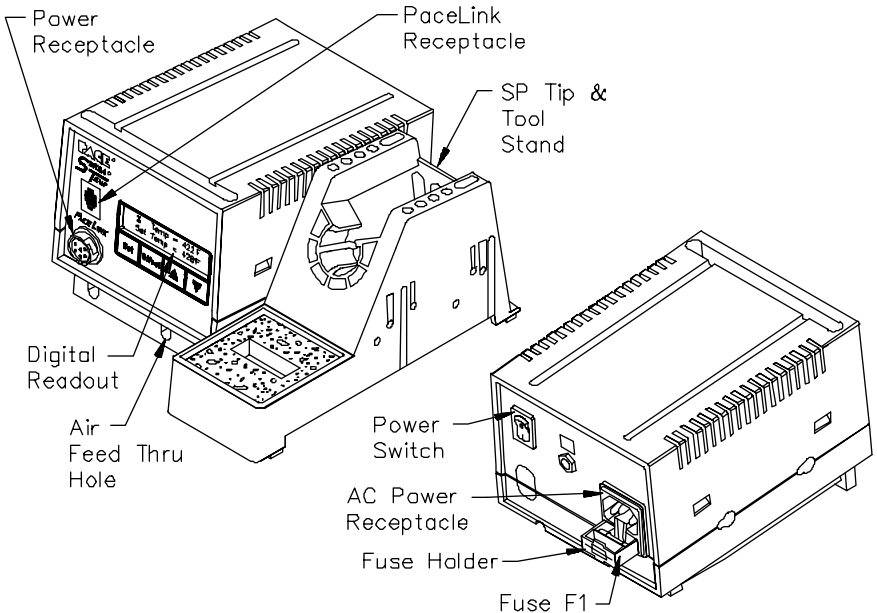

Safety

The following are safety precautions which personnel must understand and follow when using or servicing this product.

1. SensaTemp handpiece heaters and installed tips are hot when the handpiece is powered on. **DO NOT** touch either the heater or the tip. Severe burns may result.
2. The enclosed SP Tip & Tool Stand has been designed specifically for use with the Sodr-Pen (SP-1A & SP-2A) and houses the handpiece in a manner which protects the user from accidental burns. Always store the handpiece in the SP Tip & Tool Stand.
3. Always use this system in a well ventilated area. A fume extraction system such as those available from PACE are highly recommended to help protect personnel from solder flux fumes.
4. Exercise proper precautions when using materials (e.g., fluxes & solder paste). Refer to the Material Safety Data Sheet (MSDS) supplied with each material and follow to all safety precautions recommended by the manufacturer.
5. **POTENTIAL SHOCK HAZARD** - Repair procedures on this product should be performed by Qualified Service Personnel only. Line voltage parts will be exposed when the equipment is disassembled. Service personnel must avoid contact with these parts when troubleshooting the power source.

Set-Up

System

Set up the ST 40A system using the following steps and associated drawings.

1. Store the shipping container(s) in a convenient location. Reuse of these containers will prevent damage if you store or ship the system.
2. Place the Power Switch in the "OFF" or "0" position.
3. Place 4 of the supplied Rubber Feet on the base (bottom) of the power source. Remove the paper backing and place in corner indentations.

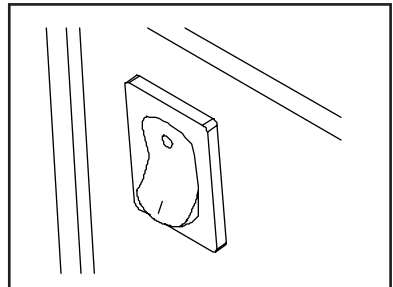

SP Tip & Tool Stand

4. Place the 4 remaining Rubber Feet on the bottom corners of the enclosed SP Tip & Tool Stand.
5. The SP Tip & Tool Stand may be used as “free standing” or may be attached to either side of the power source. Attach the stand using the following procedure.
 - a) Insert the 2 enclosed Mounting Screws (head first) into the 2 power source mounting slots shown. Slide the screws toward the rear of the power source.
 - b) Place the SP Tip & Tool Stand beside the power source, inserting ends of the 2 Mounting Screws into the 2 SP Tip & Tool Stand lower mounting holes shown.
 - c) Install a knurled Thumb Nut onto the end of each Mounting Screw. Tighten Thumb Nuts to secure the stand in position.
6. Place the supplied sponge in the SP Tip & Tool Stand using the following procedure.
 - a) Remove the 2 small punched out center portions of the sponge & place into the sponge well of the stand in the position shown.
 - b) Place the large sponge section into the sponge well as shown.
 - c) Dampen the sponges with water.
7. Place the handpiece into the SP Tip & Tool Stand.

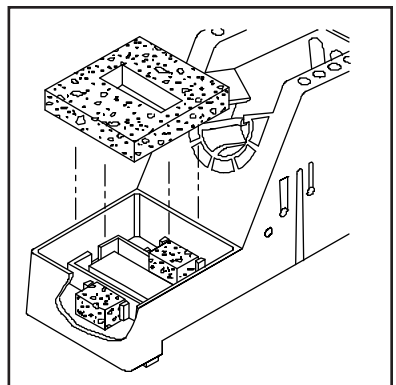
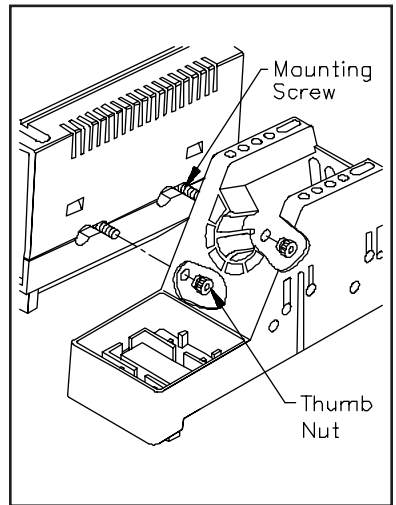
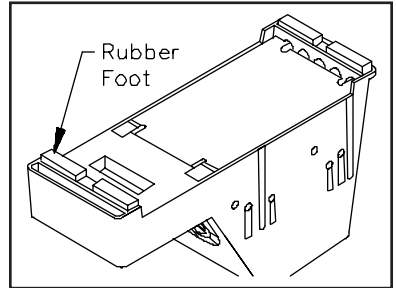

Set-Up

Handpiece Connection

8. Connect the handpiece connector plug into the Power Receptacle in the following manner.
 - a) With the Connector Key end facing the power source, turn the Locking Ring fully counterclockwise .
 - b) Align the Connector Key with the Receptacle Keyway.
 - c) Insert the connector into the Power Receptacle.
 - d) Turn the Locking Ring fully clockwise to secure in place.

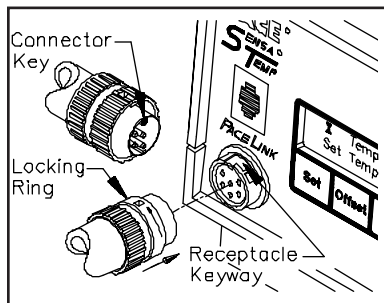

Air Hose Routing

When using an Air Handpiece (e.g., SX-70 Sodr-X-Tractor) or a Tip-Evac Fume Extraction System, route any associated air hose(s) through the 2 Air Hose Feed Thru holes located on the bottom of the power source.

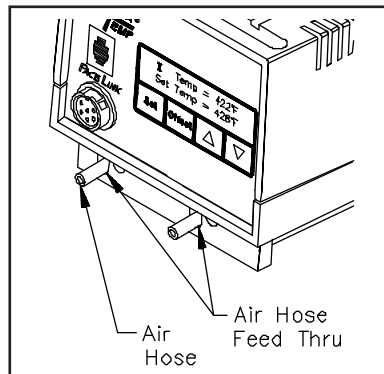

System Power Up

9. Insert the female end of the power cord into the AC Power Receptacle at the rear panel of the power source.
10. Plug the the prong end (male end) of the power cord into a 3 wire grounded AC supply receptacle. The system is now ready for operation.

CAUTION

To insure operator safety, the AC supply receptacle must be checked for proper grounding before initial operation.

11. Read the “Operation” section of this manual thoroughly before operating the system.

Heater Burn In

To insure optimum performance and long life, new handpieces must undergo a burn in procedure. A Red tag is attached to each handpiece and with replacement heater assemblies which describes the proper procedure. The ST 40A system however, has a Burn In feature which, when activated will burn in the heater in a similar manner as is described on the tag. Use this feature when setting up a new ST 40A system (burn in all handpieces) or when replacing a handpiece heater assembly.

NOTE

As received from the factory, the Set Temperature will be "OFF". The system power source must have an entered Set Temperature before using this feature. If the Set Temperature is "OFF", enter a temperature at this time (see Operation section of this manual).

Ensure that the system is placed in a well-ventilated area. Smoke will be emitted from the heater assembly during the burn in cycle.

Use the following instructions to perform the Heater Burn In procedure.

1. Place the Power Switch in the "OFF" (0) position.
2. Ensure that the handpiece is connected to the system power source.
3. Some handpieces heater assemblies are shipped with a plastic cap installed on the end of the heater assembly. If this cap is present, remove the cap and discard. The cap is used for shipping purposes only.

4. Press and hold the **Set** and Scroll Up (▲) keys together.

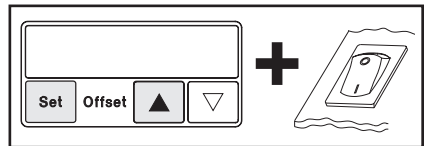

5. Place the Power Switch in the "ON" (I) position. The Digital Readout will display "VERSION X.X".

6. Immediately release the **Set** and Scroll Up (▲) keys.

7. Press the **Set** Key to enter the Burn In Mode.

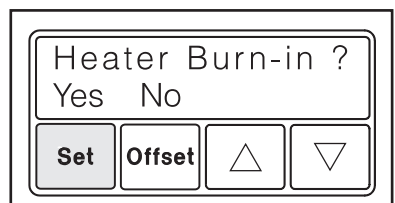

Set-Up

8. The system is now in the Burn In Mode. The handpiece heater will begin to heat up with the temperature displayed (in °C or °F) on the Digital Readout. The message “Heater Burn In” (flashing off and on) and an hour glass graphic will appear and will continue to be displayed until the conclusion of the burn in cycle.
9. The temperature of the heater will stabilize at 315°C (or 600 °F) and remain at that temperature for 10 minutes.
10. At the conclusion of the 10 minute period, the heater temperature will increase to 427°C (or 800°F) and remain at that temperature for 15 minutes.
11. At the conclusion of the 15 minute time period, power is removed from the heater. The Digital Readout will display “Burn In Complete”. Press and release the **Set** Key to “EXIT” Heater Burn In and return the system to the Temperature Display Mode (normal operation).

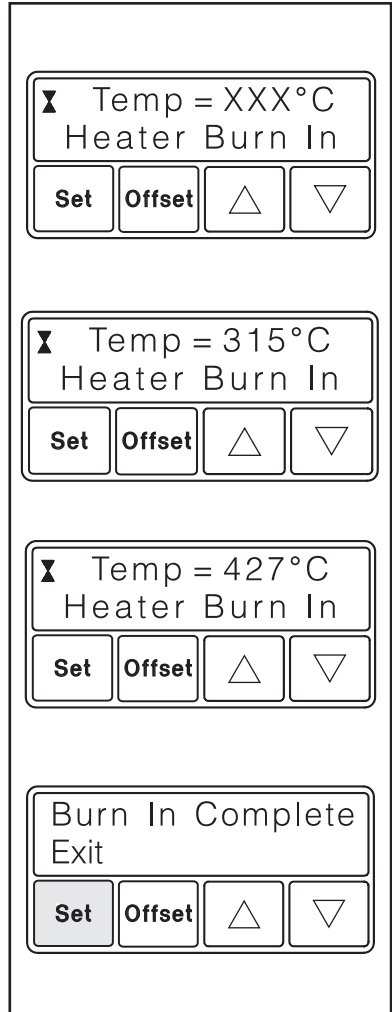

NOTE

The microprocessor circuitry within the unit monitors the system to insure proper results. If any abnormalities are encountered, the Burn In cycle will be interrupted and an error message displayed. If this situation should occur, turn the system off and perform the procedure again. If the cycle is interrupted a second time, refer to Table V and check for handpiece malfunction. If a second handpiece is available, perform the procedure using that handpiece.

PACELINK

The PaceLink Receptacle on the front panel of the power source allows the you to link your ST 40A system to the **AUTO SNAP-VAC** and Controllable **PRESSURE** features of a ST 60 system . If an air handpiece (SX-70, TP-65 or TJ-70) is connected to the ST 40A, actuation of its finger switch will activate air flow through the **AUTO SNAP-VAC** and Controllable **PRESSURE** ports of the ST 60 system. To link your ST 40A system to a ST 60 system, perform the following procedure.

1. Place your ST 40A & ST 60 systems adjacent to each other (side by side or stacked one on top of the other).
2. Use a PaceLink cable (available from your local PACE distributor)) to connect the systems. Place the plugs ends of the cable into the **PaceLink** Receptacles on both systems.
3. Ensure that a VisiFilter assembly is connected to the ST 60 **AUTO SNAP-VAC** Port.
4. Connect the Air Hose of the handpiece currently in use to the VisiFilter assembly or Controllable **PRESSURE** Port.

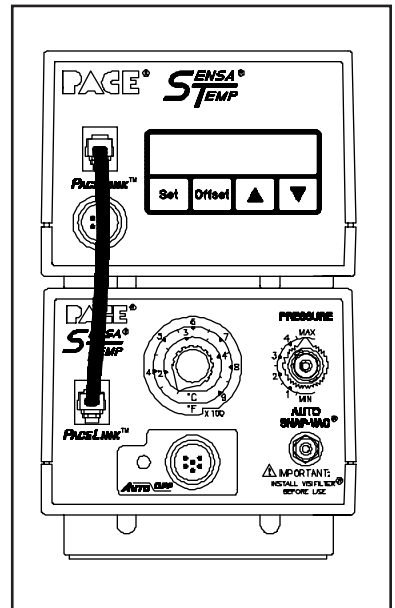

CAUTION

Systems connected together through the PaceLink must be used and controlled by a single operator. Any attempt to operate by more than one individual can create a hazard condition and will cause a deterioration in performance.

Ensure that only one air hose is connected to the **AUTO SNAP-VAC** or Controllable **PRESSURE** port at one time. Attachment to both ports simultaneously will cause a deterioration in performance.

Handpiece Tips

Tip Selection & Use

1. **HEAT TRANSFER:** Maximize thermal transfer by selecting the shortest, fattest tip with the largest surface contact area which appropriately fits the work. Keep the tip clean and freshly tinned, and clean the work of oxides or other residues.

When soldering, angle the tip to the joint so that there is maximum surface contact area. The use of a “solder bridge” to enhance “thermal linkage” will also improve heat transfer.

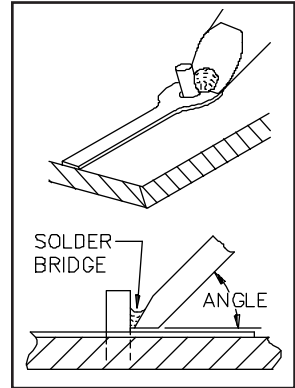

2. **TIP ACCESS & VISIBILITY:** The tip selected must easily contact the joint without touching the board substrate, adjacent components or other solder joints.

Longer, thinner, more tapered tips allow the operator to more easily access and view the solder joint during soldering for better process control. However, such tips generally have much less heat transfer ability than shorter, fatter tips.

3. **TIP TEMPERATURE:** Use the lowest tip temperature which will achieve rapid yet controllable melt of the entire joint(s). Begin with a temperature of 316°C (600°F) and adjust as necessary to suit the particular application and operator skill level. Lower tip temperatures reduce the risk of damage and increase tip life.

4. **SMT REMOVAL:** Tips for SMT removal applications must fit over (or around) the component body, and contact all the solder joints at once. When all the solder joints reflow completely, remove the component.

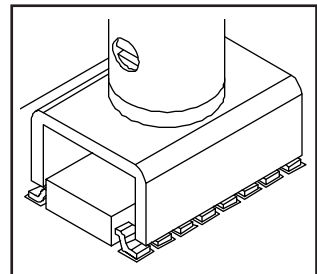

5. **HANDPIECES:** The SP-2A Sodr-Pen (which comes standard with your ST 40A system) uses 3/16" shank tips providing maximum heat transfer for Surface Mount and multilayer board applications.

The optional SP-1A Sodr-Pen uses 1/8" shank tips and features a slimmer, more compact heater for easier access on densely populated assemblies.

Shown below is a partial listing of available single point and SMT tip configurations. Contact your local authorized PACE distributor for the Tip & Applications catalog which contains a complete list of tips.

3/16" SHANK TIPS (for SP-2A Sodr-Pen)		3/16" SHANK EXTENDED REACH TIPS (for SP-2A Sodr-Pen)	
DESCRIPTION	PART #	DESCRIPTION	PART #
1/64" Conical	1121-0357	1/64" Conical	1121-0528
1/64" Bent Conical	1121-0363	1/32" Conical	1121-0527
1/32" Chisel	1121-0359	1/16" Chisel	1121-0533
1/32" Bent Chisel	1121-0361	3/32" Chisel	1121-0529
1/32" Conical	1121-0336	1/8" Chisel	1121-0530
1/16" Chisel (MicroFine)	1121-0349	3/16" Chisel	1121-0531
1/16" Chisel	1121-0335	Single Sided Chisel	1121-0532
1/16" Chisel (High Capacity)	1121-0414	3/16" SHANK THERMO-DRIVE TIPS (for SP-2A Sodr-Pen)	
1/16" Chisel (Extended Reach)	1121-0499		
1/16" Bent Chisel (Ext. Reach)	1121-0500	1/64" Conical	1121-0516
3/32" Chisel	1121-0360	1/64" Bent Conical	1121-0526
1/8" Chisel	1121-0337	3/64" Chisel	1121-0524
3/16" Chisel	1121-0358	3/64" Bent Chisel	1121-0525
Single Sided Chisel	1121-0406	1/16" Chisel	1121-0510
1/4" Flat Blade	1121-0402	1/8" Chisel	1121-0518
0.40" Flat Blade	1121-0305	1/8" SHANK TIPS* (for SP-1A Sodr-Pen)	
Mini-Wave	1121-0490		
*These tips (1/8" shank) can be installed in the SP-2A Sodr-Pen using the PACE AdapTip (Part Number 1360-0083-P1).		1/32" Conical	1121-0503
		1/16" Chisel	1121-0502
		1/8" Chisel	1121-0501

Table I. Single Point Tips

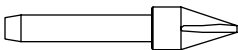

3/16" Shank Thermo-Drive Chisel Tip

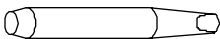

3/16" Shank Chisel Tip

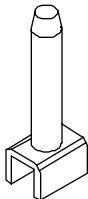

SOIC Tip

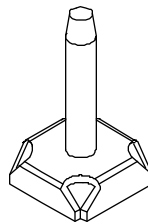

Socket Tip

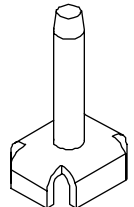

FlatPack Tip

Handpiece Tips

Tip Installation

For maximum productivity and proper fit, install tips into your Sodr-Pen when the heater is hot.

CAUTION

Hold the handpiece with the heater pointed up at an angle to prevent injury to personnel.

1. Select the proper tip for your application. Refer to Table I or the PACE Tip & Applications Catalog.
2. Install the selected tip in the following manner.
 - a) Hold the handpiece with the heater up at an angle (heater hot).
 - b) Insert the Tip all the way into the heater bore using the supplied Tip Tool.
 - c) Gently tighten the heater Set Screw.
3. Recheck the tip Set Screw periodically to insure that it remains snug.

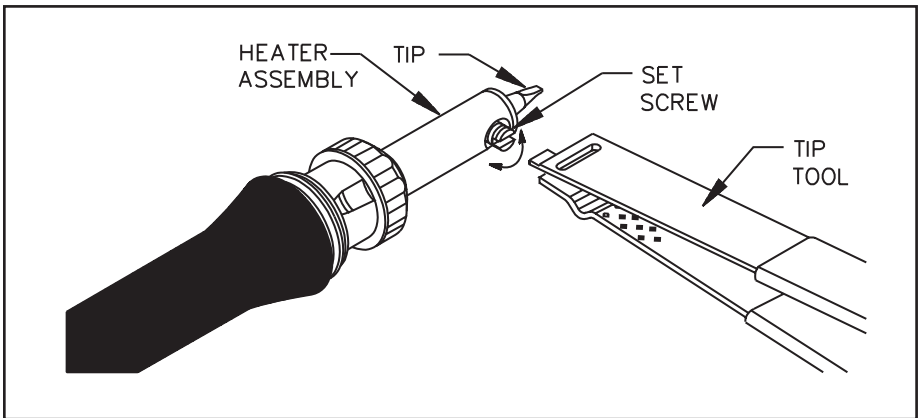

NOTE

Periodically, clean the heater bore with a properly sized wire brush (3/16" O.D. for SP-2A and 1/8" O.D. for SP-1A) to insure optimum heat transfer and proper tip grounding.



Quick Start - Basic Operation

Introduction

The ST 40A system is very easy to operate. As received from the factory, the system can be quickly set up for use in standard soldering operations. Simply perform the following Quick Start Procedure to begin system operation.

Quick Start Procedure

1. Insure that the Set-Up procedure has been performed; including the Heater Burn In procedure. Check for the following:
 - a) Handpiece connection to the power source.
 - b) Proper tip installed in handpiece.
 - c) Power cord connection between house AC supply receptacle and the power source.

2. Turn the Power Switch "On" ("1").

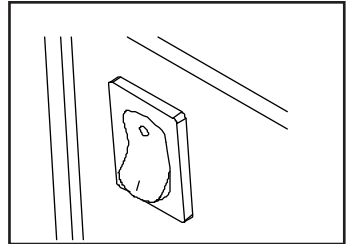

3. Press the **Set** Key.

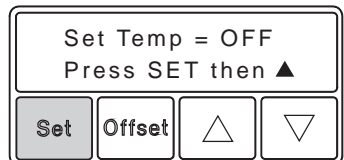

Quick Start - Basic Operation

4. Immediately press the Scroll Up (▲) Key to increase the desired Tip Temperature. Press the Scroll Down (▼) Key to decrease the desired Tip Temperature.

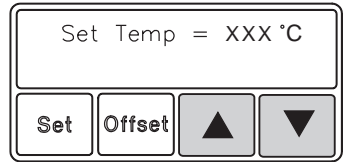

5. Press the Set Key.

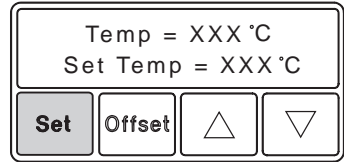

6. Observe the Digital Readout as the "Set Temp" stabilizes at the desired Tip Temperature

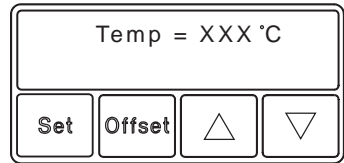

NOTE

Read the "Operation" and "Set-Up Mode" sections of this manual to utilize the full capabilities of the system. This is especially important when using large soldering tips or other SensaTemp handpieces.

Operation

IMPORTANT

PACE recommends that you not read the "Set-Up Mode" section until after you feel comfortable with system operation. Please read the following "Operation" section thoroughly before changing the system settings.

Definitions

Please read and become familiar with the definitions of each of the following terms which are used repeatedly in the following operational procedures.

AUTO OFF - Safety feature which turns power off (30-120 minutes) after the system has entered Temperature Setback.

OPERATING TIP TEMPERATURE - The true tip temperature at which the handpiece tip operates at any given time. This temperature is displayed on the Digital Readout ("Temp = XXX") in normal operation.

SET TIP TEMPERATURE - The operator selected idle tip temperature ("Set Temp = XXX") entered into the system memory in Tip Temperature Set Mode for the connected handpiece/tip combination.

SET-UP MODE - Mode of operation in which the operator can quickly and easily adjust the system parameters (e.g., temperature limits, password, setback time).

TEMPERATURE DISPLAY MODE (normal operation) - Normal operating mode of the system in which the Operating Tip Temperature is displayed. Additionally, the Set Tip Temperature will also be displayed after temperature adjustment until the temperature stabilizes. In Temperature Display Mode, "***" will be displayed on the Digital Readout if the Tip Offset Constant value is greater than 0.

TEMPERATURE SETBACK - System feature which, when enabled, will independently set back the Set Tip Temperature to 177°C (350°F) after a user selected period of handpiece inactivity (5 to 120 minutes settable in 1 minute increments). This feature is enabled (or disabled) in the Set-Up Mode.

TIP OFFSET CONSTANT - Specific value for a given handpiece/tip combination upon which the system automatically calculates the correct Tip Temperature Offset at any entered Set Tip Temperature. This value is the temperature loss (Tip Temperature Offset) at 371°C (700°F).

TIP OFFSET MODE - Mode of operation in which the system's Tip Offset Constant value can be viewed or altered. In this mode, the stored value appears on the top line of the Digital Readout (Set Tip Temperature appears on the bottom line).

TIP TEMPERATURE SET MODE - Mode of operation in which the Set Tip Temperature can be viewed or altered. In this mode, the stored value appears on the top line of the Digital Readout (the Tip Offset Constant appears on the bottom line if greater than 0).

TIP TEMPERATURE OFFSET - Difference in value between the temperature measured by the temperature sensor (at the heater) and the true temperature of the tip at a given Set Tip Temperature.

NOTE

As with any system, Set and Operating Tip Temperatures are only exactly equal when the handpiece is idling (unloaded at equilibrium). During use, (i.e., under load) the Operating Tip Temperature will usually be lower.

Auto Tip Temperature Compensation

Differences between the temperature settings and true tip temperatures are negligible when using Thru-Hole, single point soldering tips. With any heating system however, True Tip Temperatures can differ greatly from temperature settings when using larger SMT soldering tips. This difference is called Tip Temperature Offset. The ST 40A Auto Tip Temperature Compensation feature lets you set and display true tip temperatures regardless of size and type of tip or handpiece. PACE recommends the use of the Tip & Temperature Selection System booklet (PACE P/N 5050-0251) as a guide to accurately set and maintain a true tip temperature for any size and type of SMT tip.

Password

The Password feature of the ST 40A system, when activated, will prevent unauthorized alteration of stored system temperature parameters and feature settings (refer to Table I, “Factory Settings”). If a Password has been installed, the Digital Readout will display an instruction to enter the Password (a 4 key sequence of the keys on the system front panel) when a setting change is attempted.

Entry of the correct Password at this point will allow the operator to proceed with the desired changes. Once the correct Password has been entered, the operator can continue to make changes to Tip Temperature and Tip Temperature Offset settings. To reactivate the Password protection, simply press either the Scroll Up or Scroll Down key when the system is in the Temperature Display Mode (normal operation). The Password protection will also be reactivated if the system is turned off and then back on. Refer to the “Set-Up Mode” section of this manual for instructions on entering, changing or removing a Password.

Operation

Basic Operation

The ST 40A system is very easy to adjust and operate. The following instructions direct the operator to adjust temperature settings to levels that are arbitrary to familiarize the operator with the system. The illustrations depict temperature in °C.

1. Insure that the system is properly prepared for operation. Refer to the “Set-Up” portion of this manual. The handpiece selected for your application should be connected to the unit. Refer to the Tip Selection & Use section of this manual for more detailed information on selection of the proper tip, handpiece and temperature options for your particular application.

Digital Readout Operation

2. The Digital Readout provides a 2 line LCD display of the temperature information. The Digital Readout will show:

- a) The software version of the system power source for 2 seconds on initial power up.



- b) Temperature display in °C or °F (programmable in Set-Up Mode).

- c) The Operating Tip Temperature (“Temp = XXX”) and the Set Tip Temperature (“Set Temp = XXX”).

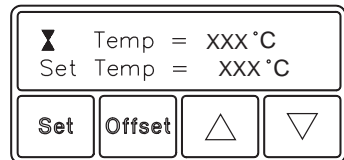

- d) The Operating Tip Temperature when it stabilizes. The Set Tip Temperature will disappear and only the Operating Tip Temperature display will remain. The system is now in Temperature Display Mode (normal operation).

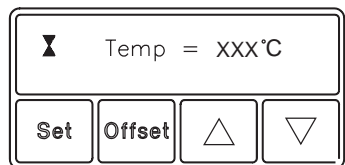

- e) An hour glass icon at the top left corner of the Digital Readout if the Temperature Setback/Auto Off features are enabled. This icon will flash 1 minute prior to Temperature Setback and will continue flashing in Temperature Setback.



- f) The Set Tip Temperature ("Set Temp = XXX") in the Tip Temperature Set Mode, and the Tip Offset Constant value ("Offset = XXX") for offset values greater than 0.

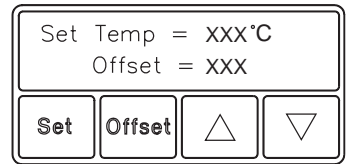

- g) The Tip Offset Constant ("Offset = XXX") above the Set Tip Temperature ("Set Temp = XXX") in the Tip Offset Mode.

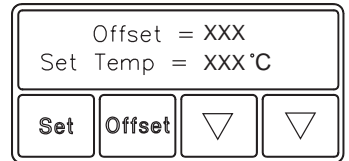

- h) "***" in Temperature Display Mode, if the stored Tip Offset Constant value is greater than 0.

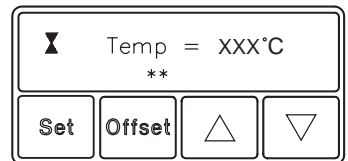

- i) A variety of text messages to denote system status (e.g., time to setback, Password entry instruction etc.).

Operation

Power Up

3. Turn the Power Switch ON ("1").

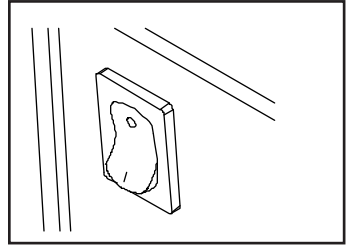

NOTE

If the Power Receptacle does not have a handpiece attached, "Open Sensor Check Handpiece" will be displayed on the Digital Readout.

Panel Controls

4. With a handpiece connected to the system the Digital Readout will display the stored Set Tip Temperature and the Operating Tip Temperature. If the Digital Readout displays "Set Temp = OFF" (factory setting), proceed to step 5.

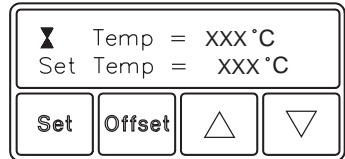

Allow sufficient time for the handpiece to heat and the Operating Tip Temperature ("Temp = XXX") to stabilize at the Set Tip Temperature. The Digital Readout will now display only the Operating Tip Temperature (plus "***" if the stored Tip Offset Constant value is greater than 0).

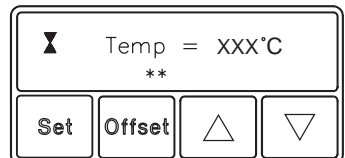

5. Press the **Offset** Key. The Digital Readout will display the Tip Offset Constant value (which is "0" as received from the factory). If the **Offset** Key is immediately pressed again, or if no other operation occurs within 5 seconds, the Digital Readout will revert to the Temperature Display Mode (normal operation).

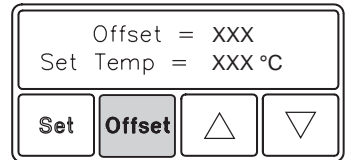

NOTE

If a Password has been previously programmed into the system, a message will be displayed on the Digital Readout (when a setting change is attempted) requiring the operator to enter the correct Password before adjusting the system parameters. Refer to "Password" in the "Operation" portion of this manual.

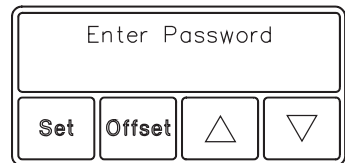

6. If the Digital Readout reverts to the Temperature Display Mode (normal operation), press the **Offset** Key once to enter Tip Offset Mode. Immediately press and hold the Scroll Up (\blacktriangle) Key. Observe the displayed Tip Offset Constant value increase, first in 1° and then in 10° increments. Release the key when the Tip Temperature Offset value reads "033" for $^\circ\text{C}$ ("060" for $^\circ\text{F}$).

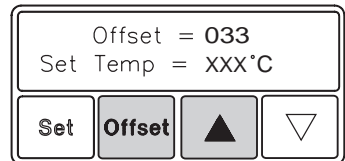

7. While still in the Tip Temperature Offset Mode, press and hold the Scroll Down (\blacktriangledown) Key. Observe the displayed Tip Offset Constant decrease first in 1° and then in 10° increments. Release the key when the Digital Readout displays "028" for $^\circ\text{C}$ ("050" for $^\circ\text{F}$).

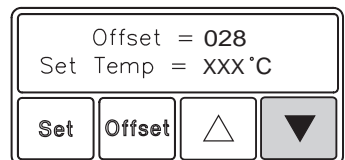

Operation

8. Immediately press the **Offset** Key to exit the Tip Offset Mode and enter the new Tip Offset Constant into the system memory.

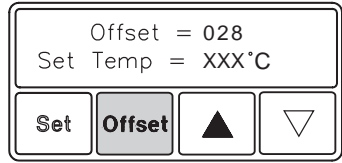

NOTE - "***" appears on the Digital Readout if a Tip Offset Constant value greater than 0 (the default) has been stored in system memory. Refer to "Auto Tip Temperature Compensation" for a complete discussion of Tip Temperature Offset function.

9. Press the **Set** Key. This is Tip Temperature Set Mode. As received from the factory, the Digital Readout will display "Set Temp = OFF". If the **Set** Key is immediately pressed again, or if no other operation occurs within 5 seconds, the Digital Readout will revert to the Temperature Display Mode (normal operation).

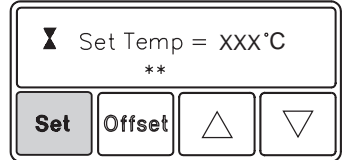

10. If the Digital Readout reverts to the Temperature Display Mode (normal operation), press the **Set** Key once to enter Tip Set Mode. Immediately press and hold the Scroll Up (▲) Key. Observe as the displayed Set Tip Temperature increases first in 1°, then in 10° increments (°C or °F). Release the key when the Digital Readout reads 316°C (or 600°F).

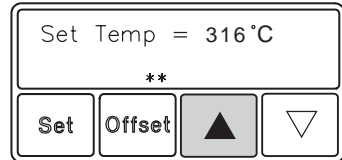
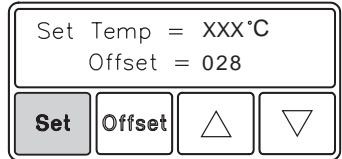

Immediately press the **Set** Key once again. Observe the Digital Readout as the Operating Tip Temperature reaches 316°C (or 600°F). The Digital Readout will display both the Set Tip Temperature and the (true) Operating Tip Temperature.

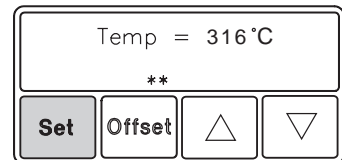

When the Operating Tip Temperature reaches the Set Tip Temperature and stabilizes, only the Operating Tip Temperature will be displayed.

11. Press the **Set** Key once to enter the Tip Temperature Set Mode. Immediately press & hold the Scroll Down (▼) Key. Observe as the displayed Set Tip Temperature decreases first in 1° and then in 10° increments (°C or °F). Release the key when the Digital Readout displays 288°C (550°F). Immediately press the **Set** Key once again.

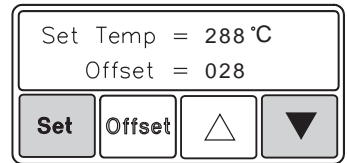

12. Immediately press the **Set** Key (or wait 6 seconds) to exit the Tip Temperature Set Mode and observe the Operating Tip Temperature decrease to 288°C (550°F).

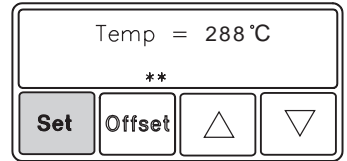

13. The system will retain the stored Set Tip Temperature and Tip Offset Constant even when power is removed.

14. Turn the Power Switch to the OFF (“0”) position. Turn the switch back to the ON (“1”) position.

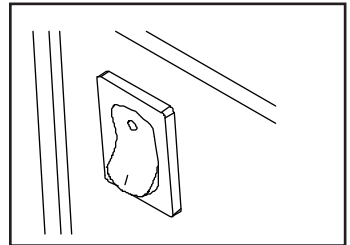

15. Press the **Set** Key. Notice that the system has retained the stored Set Tip Temperature and Tip Offset Constant in memory. Immediately press the **Set** Key once again to exit Tip Temperature Set Mode.

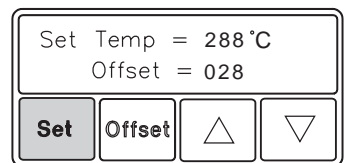

16. In order to prevent a handpiece/tip combination from inadvertently operating at an incorrect Tip Temperature, the system will not retain a stored Tip Offset Constant if a handpiece is disconnected with power on. The Tip Offset Constant will return to the default value of “0” (for °C or °F). Disconnect the handpiece. Reconnect the handpiece.

IMPORTANT

Tip Offset values change as the Set Tip Temperature is changed. The ST 40A system embodies a "Dynamic Offset" feature which automatically adjusts the Tip Offset value as you change your Set Tip Temperature. Refer to "Auto Tip Temperature Compensation" for more detailed information on this important feature. **PACE recommends the use of the Tip & Temperature Selection System booklet (PACE P/N 5050-0251) as a guide to accurately set and maintain a true tip temperature for any size and type of SMT tip.** Using this booklet, you only need to enter the listed Tip Offset Constant for your tip (stored value is for Tip Offset at 371°C or 700°F).

Always set the appropriate Tip Offset Constant for the selected handpiece/tip combination before entering the desired Set Tip Temperature. The maximum possible Offset is "139" for °C ("250" for °F). The Set Tip Temperature + the Dynamically Adjusted Tip Offset value (usually different from the entered Tip Offset Constant) cannot exceed 489°C (912°F). If this limit is exceeded, the system will automatically lower the maximum possible Set (and Operating) Tip Temperature accordingly.

17. Press the **Offset Key**. Notice that the Tip Offset Constant has now changed to the default value of "000" (for °C or °F). Whenever the channel becomes inactive (no connected handpiece), the Tip Offset Constant automatically reverts to the default.

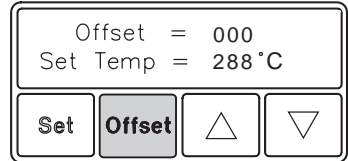

18. While in Tip Offset Mode, use the Scroll Up (▲) and Scroll Down (▼) Keys to set Tip Offset Constant value as desired. Press and release the **Offset Key** to exit Tip Offset Mode and enter this value into system memory.

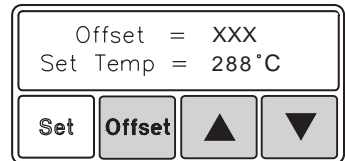

19. Press the **Set Key** and use the Scroll Up (▲) and Scroll Down (▼) Keys to enter your desired Set Tip Temperature. Press the **Set Key** again to enter Temperature Display Mode (normal operation).

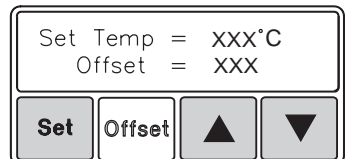

Temperature Setback

To preserve tip life and save energy, the ST 40A system can be programmed to automatically set back its Tip Temperature to 177°C (350°F) after a selected period of handpiece inactivity (adjustable 5-120 minutes in Set-Up Mode). As received from the factory, this feature is enabled. Refer to the “Set-Up Mode” section of this manual to disable or adjust the time-out period of this feature. The operator can also force the system into Temperature Setback. The Auto Off Safety feature is also enabled automatically when Temperature Setback is enabled.

NOTE

If the Set Tip Temperature is less than 177°C (350°F), the system will remain at the lower temperature in Temperature Setback.

Activation

There are two ways in which the system will activate the Temperature Setback feature.

1. **AUTOMATIC ACTIVATION** - The system memory can be programmed so that the system will automatically activate Temperature Setback after a selected period (5-120 minutes) of handpiece inactivity. See the “Set-Up Mode” section for details on programming this feature.
2. **MANUAL ACTIVATION** - The operator can manually force the system to place the system in Temperature Setback by performing the following procedure.
 - a) Press and hold the Scroll Down (▼) Key.
 - b) Press the Scroll Up (▲) Key.
 - c) Release both keys.

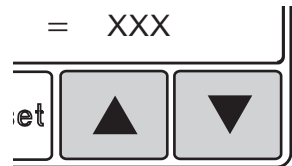

Operation

Temperature Setback is indicated by the following.

1. The hour glass icon at the top left corner of the Digital Readout will start flashing 1 minute before entering Temperature Setback and continue to flash while in Temperature Setback.
2. The Operating Temperature will stabilize at 177°C (350°F) unless the Set Tip Temperature is lower (see NOTE above).
3. The bottom line of the Digital Readout will display the time remaining to Auto Off in hours and minutes.

Operation

Exiting Temperature Setback

Listed below are 2 different ways to exit Temperature Setback.

1. Press and release either Scroll Key (▲ or ▼). This is the preferred method.
2. Method “1” is preferred but you can turn the Power Switch “OFF” (0) and then back “ON” (1).

Set Tip Temperature and Tip Offset Constant values will be simultaneously restored. Observe the Digital Readout as the Operating Tip Temperature stabilizes at the Set Tip Temperature. For optimum performance, do not attempt to use the attached handpiece until the Set Tip Temperature is achieved.

Auto Off Safety System

The Auto Off safety system of the ST 40A system removes power 30-120 minutes (adjustable in Set-Up Mode) after entering Temperature Setback. This feature is automatically enabled when Temperature Setback is enabled.

Operation

When the system has entered Temperature SetBack, an Auto Off timer within the system circuitry will start running:

1. If any key is pressed during the selected time out period, the Auto Off timer is reset.
- 2 The bottom line of the Digital Readout displays “X:XX to Auto OFF” (“X” = 0 thru 9), alerting the operator as to the length of time remaining (in hours and minutes) before the system enters Auto Off.
- 3 At the end of the time out period, the system will enter Auto Off. Power is removed and the Digital Readout will display “System is OFF Press Any Key”.

Exiting Auto Off

Auto Off can be exited; returning to normal operation by

1. Pressing any key
- OR**
2. By turning the Power Switch OFF (“0”) and then back ON (“1”).

FACTORY SETTINGS

The ST 40A system comes equipped with a number of features which may be adjusted, enabled or disabled as desired by the user. Listed below are the features and factory settings of each. To change and/or learn about any of these features, refer to the applicable part of the “Set-Up Mode” portion of this manual.

FEATURE	FACTORY SETTING
Password	Disabled
Temperature Setback	Enabled
Setback Time	90 Minutes
Auto Off (Enabled automatically when Temperature Setback is enabled)	Enabled
Time To Auto Off (after entering Setback)	30 Minutes
Default Temperature Scale (°C/°F)	°F
Set Tip Temperature	"OFF"
"LO" (lower) Temperature Limit	204°C (400°F)
"HI" (upper) Temperature Limit	482°C (900°F)
Tip Offset Constant	"0"

Table II. Factory Settings

Set-Up Mode

Introduction

The menu driven Digital Readout of the ST 40A system in the Set-Up Mode allows you to easily customize your system. In most cases, the operator is directed as to which key(s) to press in order to proceed. In cases where specific instructions are not displayed, simply press the **Set Key** to proceed to the next step. No calibration adjustments are necessary to maintain the accuracy of the system.

In Set-Up Mode, you can:

1. Change the Upper and Lower Temperature limits.
2. Set the Default Temperature scale to °F or °C as desired.
3. Enable or disable the Temperature Setback/Auto Off features.
4. Adjust the time-out period of the Temperature Setback & Auto Off features.
5. Enter, remove or change a Password.

The following instructions should be performed to familiarize the operator with the system.

Entering Set-Up Mode

1. Place Power Switch in the "OFF" ("0") position.
2. Press and hold the **Set** and Scroll Down (▼) Keys together.
3. Place Power Switch in the "ON" ("1") position. The Digital Readout will display "VERSION X.XX" and change to read "Password Needed ?"
4. Release the **Set** and Scroll Down (▼) Keys. The system is now in Set-Up Mode. "Enter Old Password" will be displayed if a Password is currently stored in system memory.

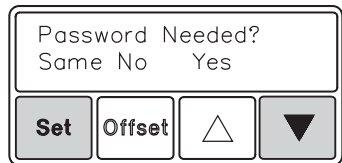
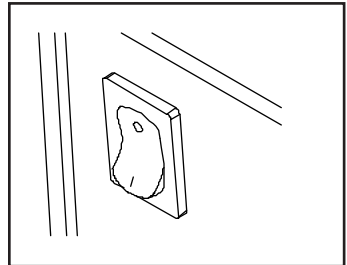

Operation

Password

5. If a Password has been previously stored in system memory, enter the 4 key sequence Password.

6. At this point the Digital Readout will ask you:

a) If you would like to retain the "Same" Password (if previously stored) in the system. If you wish to retain the "Same" Password, press the Key directly beneath the word "Same" (**Set Key**).

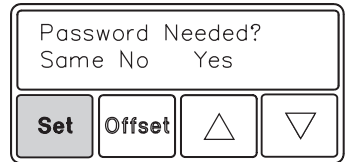

b) If you do not wish to have a Password stored in the system. If this is the case, press the key directly beneath the word "No" (**Offset Key**) on the Digital Readout. Any previously stored Password will be removed from the system.

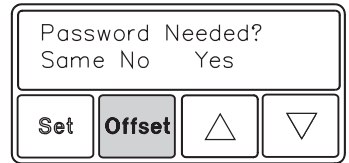

c) If you wish to enter a new Password, press the key directly beneath the word "YES" (Scroll Up (▲) Key) on the Digital Readout. The Digital Readout will display "Enter New Password". Enter a new 4 key sequence Password. As each key is pressed, an asterisk (*) will be displayed.

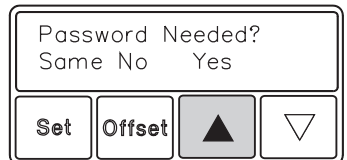

NOTE

The following steps of this procedure move you forward through the Set-Up Mode options. You may also step backward (to this point only) by pressing the **Offset Key**.

Set-Up Mode

°F/°C Digital Readout

7. The Digital Readout will now display “Display is °F (or °C) Push ▲ to Change”. Press the Scroll Up (▲) Key if you wish to change the temperature readout (°C or °F).

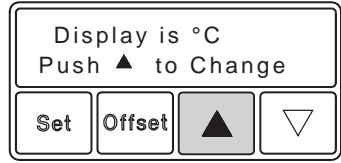

8. Press the Set Key.

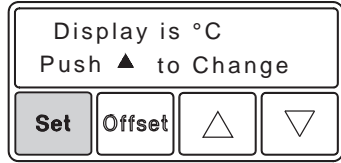

Temperature Limits

NOTE

The HI (upper temperature) Limit setpoint must be set above or equal to the LO (lower temperature) Limit setpoint.

LO (Lower) Temperature Limit Setpoint

9. The top line of the Digital Readout will now display “Lo Limit = XXX°C (or °F)”. This is the stored value of the Lower Temperature Limit in increments of 1° (F or C).

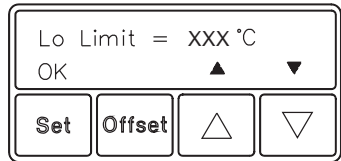

10. Press Scroll Keys as necessary to increase (Scroll Up (▲) Key) or decrease (Scroll Down (▼) Key) the Lower Temperature Limit value.

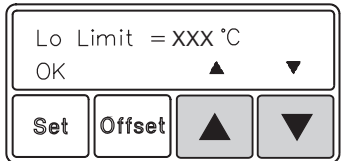

11. Press and release the Set Key.

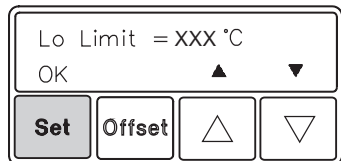

HI (Upper) Temperature Limit Setpoint

12. The Digital Readout now displays “Hi Limit = XXX °C (or F)”. This is the stored value of the Upper Temperature Limit.

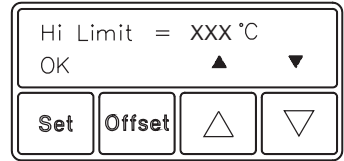

13. Press Scroll Keys as necessary to increase (Scroll Up (▲) Key) or decrease (Scroll Down (▼) Key) the Upper Temperature Limit value.

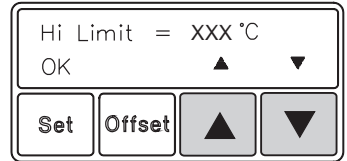

14. Press and release the **Set** Key.

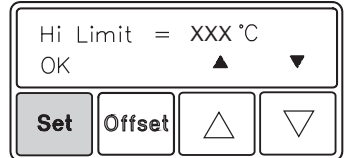

Temperature Setback

15. The Digital Readout now displays “Setback Disabled Push ▲ to Change”. Press the Scroll Up (▲) Key if you wish to change the current selection. As received from the factory, the Temperature Setback is Disabled.

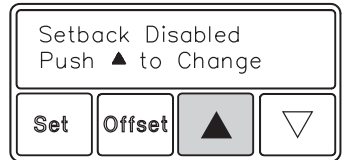

16. Press and release the **Set** Key.

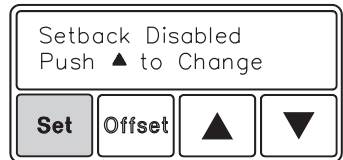

17. The top line of the Digital Readout will now display “Setback = X:XX” indicating time to Auto Setback in hours and minutes (5 minutes minimum, 2 hours max.) in increments of 1 minute. To change the time period, press the Scroll Keys. Press the Scroll Up (▲) Key to increase the time period. Press the Scroll Down (▼) Key to decrease the time period.

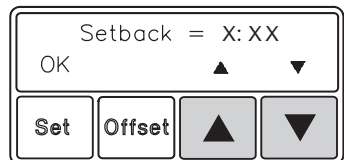

Set-Up Mode

18. Press the **Set** Key.

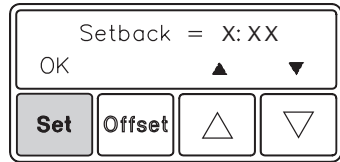

Auto Off Safety System

19. The Digital Readout now displays “Auto Off = X:XX” indicating time to Auto Off in hours and minutes (30 minutes minimum, 2 hours max.) in increments of 1 minute. To change the time period, press the Scroll Keys. Press the Scroll Up (▲) Key to increase the time period. Press the Scroll Down (▼) Key to decrease the time period.

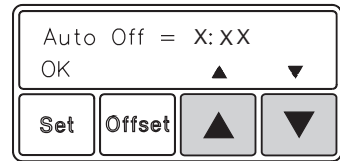

20. Press the **Set** Key.

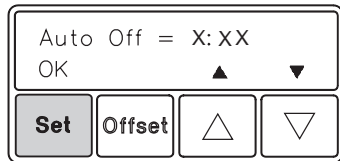

21. The Digital Readout now displays “Exit Setup? Yes (over **Set** Key) No (over **Offset** Key)”. If you wish to change any of the previously stored parameters (except Password), press the **Offset** Key and perform steps 7 through 21. Press the **Offset** Key 2 times to back up to step 6 (Password).

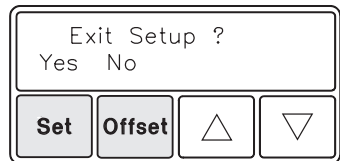

22. Press the **Set** Key to exit the Set-Up Mode and store the new settings in system memory.

Digital Readout Accuracy

No adjustments are necessary to maintain the accuracy of the system.

Digital Readout Message Codes

Listed below are message codes which may be displayed on the Digital Readout if a mistake is made by the operator (e.g., wrong Password entry) or if the system has malfunctioned.

DISPLAY MESSAGE	DESCRIPTION
<div style="border: 1px solid black; padding: 5px; margin-bottom: 5px;">Wrong Password</div> <div style="display: flex; justify-content: space-between; border: 1px solid black; padding: 2px;"> Set Offset △ ▽ </div>	<p>The incorrect Password has been entered. The displayed message will time out after 6 seconds and revert to normal operation. Enter the correct Password.</p>
<div style="border: 1px solid black; padding: 5px; margin-bottom: 5px;">Open Sensor Check Handpiece</div> <div style="display: flex; justify-content: space-between; border: 1px solid black; padding: 2px;"> Set Offset △ ▽ </div>	<p>No handpiece connected to the Power Receptacle. Connect handpiece.</p> <p>The handpiece heater assembly sensor is open. Refer to Table V to check handpiece. The displayed message may be flashing.</p>
<div style="border: 1px solid black; padding: 5px; margin-bottom: 5px;">Shorted Sensor Check Handpiece</div> <div style="display: flex; justify-content: space-between; border: 1px solid black; padding: 2px;"> Set Offset △ ▽ </div>	<p>The handpiece heater assembly sensor is shorted. Refer to Table V to check handpiece. The displayed message may be flashing.</p>
<div style="border: 1px solid black; padding: 5px; margin-bottom: 5px;">Over Current Check Handpiece</div> <div style="display: flex; justify-content: space-between; border: 1px solid black; padding: 2px;"> Set Offset △ ▽ </div>	<p>The handpiece heater assembly may be defective. Refer to Table V to check handpiece. The displayed message may be flashing.</p>
<div style="border: 1px solid black; padding: 5px; margin-bottom: 5px;">Program Error Call Pace</div> <div style="display: flex; justify-content: space-between; border: 1px solid black; padding: 2px;"> Set Offset △ ▽ </div>	<p>Power source malfunction. Call PACE Customer Service for assistance.</p>
<div style="border: 1px solid black; padding: 5px; margin-bottom: 5px;">Ram Error Call Pace</div> <div style="display: flex; justify-content: space-between; border: 1px solid black; padding: 2px;"> Set Offset △ ▽ </div>	<p>Power source malfunction. Call PACE Customer Service for assistance.</p>
<div style="border: 1px solid black; padding: 5px; margin-bottom: 5px;">A to D Error Call Pace</div> <div style="display: flex; justify-content: space-between; border: 1px solid black; padding: 2px;"> Set Offset △ ▽ </div>	<p>Power source malfunction. Call PACE Customer Service for assistance.</p>

Table III. Digital Readout Message Codes

Corrective Maintenance

Power Source

Most malfunctions are simple and easy to correct. Refer to Table IV below to clear these malfunctions.

Symptom	Probable Cause	Solution
No power to system.	Blown Fuse	Check handpiece using Table V. Replace fuse located in AC Receptacle/Fuse Holder.
No heat on handpiece.	Defective Heater	See Table V or refer to handpiece Manual.

Table IV. Power Source Corrective Maintenance

Handpieces

The following “Heater Assembly Checkout Procedures” (Table V) is applicable to all PACE SensaTemp handpieces used with the ST 20 system except for the ThermoTweez (TT-65) handpiece. Refer to either of the TT-65 manuals (5050-0300 or 5050-0336) for troubleshooting procedures pertinent to that handpiece.

Perform the procedures with the handpiece (and heater) at room temperature. If the handpiece is warm, resistance readings will be different from those shown. Disconnect the handpiece from the power source. Use a meter to check resistance across the handpiece connector plug pins as outlined in the “Checkout Procedure” column.

Symptom	Checkout Procedure	Cause	Solution
No heat on handpiece.	Check resistance - Pin 2 to Pin 5. Refer to "Heater Specifications" column. If resistance is high - -	Open Heater.	Replace Heater Assembly.
	Check resistance - Pin 3 to Pin 6. If circuit reads open - -	Open Sensor.	Replace Heater Assembly.
Handpiece overheating LED is Red.	Check resistance - Pin 3 to Pin 6. Resistance should be 110 ohms. If resistance is less than 105 ohms - -	Shorted Sensor.	Replace Heater Assembly.
Fuse blows when unit is turned on.	Check resistance - Pin 2 to Pin 5. Refer to "Heater Specifications" column. If resistance is low - -	Solder short in Handpiece.	Remove Short. Replace Heater Assembly & Fuse.
		Shorted Heater.	Replace Heater Assembly & Fuse.
No Ground on Tip.	Check resistance - Pin 4 to a NEW Tip. Resistance should be less than 2 ohms. If not - -	Oxidation in Heater Bore.	Clean Heater Bore using appropriate wire brush.
		Defective Heater.	Replace Heater Assembly.

Heater Specifications	Connector Plug Pinouts
SP-1A = 10-12 ohms	
SP-2A = 8-10 ohms	
SX-70 = 8-10 ohms	
TP-65 = 9-11 ohms	
TJ-70 = 6-8 ohms	

Table V. Heater Assembly Checkout Procedures

Corrective Maintenance

Heater Replacement

Insure that the installed heater assembly of your handpiece is defective by referring to Table V (Heater Assembly Checkout Procedures). If replacement becomes necessary, follow the procedure below for best results.

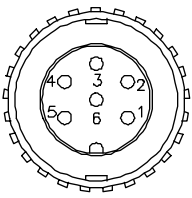
1. Disconnect the Sodr-Pen from the power source.
2. Unscrew, remove and discard the Heater Retaining Nut. If the Heater Retaining Nut does not unscrew easily, gently apply a back and forth side force to the tip end of the Heater Assembly to release the heat seal created after extended use.
3. Loosen the white plastic Strain Relief Screw (if present) located at the rear of the Handle. Gently push the Cable Assembly through the Sodr-Pen (toward the Heater Assembly) to expose the Insulator. Slide the Insulator back (toward the Handle end) to expose the 5 lead wire connections between the Heater Assembly and the Cable Assembly.
4. Disconnect the 5 Heater Assembly leads. Remove the Insulator from the Cable Assembly leads. Discard the old Heater Assembly and Insulator.
5. Feed the Cable Assembly leads back through the replacement Insulator with the notched end of the Insulator facing the Heater Assembly end. Feed the 2 Blue leads through the holes marked with the letter "B" and the 2 White leads through the holes marked "W". Feed the Green lead through the unmarked hole. Insure that the Cable Assembly leads do not become crossed with each other.
6. Plug the wire leads of the replacement Heater Assembly into the wire leads of the Cable Assembly using the table shown in the illustration as a reference. Match like colored wires. Connect the Green Cable Assembly lead to the non-insulated Heater Assembly lead. Insure that the leads do not become crossed with each other.
7. Slide the Insulator over the lead connections and against the back of the heater housing. The metal tab on the heater housing (Heater Tab) must slide in the Wide Notch (see illustration) on the end of the Insulator.
8. Gently pull the Cable Assembly back through the handpiece until the Heater Assembly rests against the plastic Handle. Gently twist the Heater Assembly (if necessary) to slide the narrow notches on the Insulator between the tabs on the inside of the Handle.

Corrective Maintenance

- Place the new metal Compression Spring over the end of the Heater Assembly .
- Install the new Heater Retaining Nut to secure the Heater Assembly and rubber Compression Spring to the Handle.
- Tighten the white plastic Strain Relief Screw (if present) located at the rear of the Handle until the screw is flush with or just above the Handle surface to secure the cable assembly in position. A replacement screw is supplied in the event that replacement becomes necessary.
- Perform the Heater Burn In procedure to insure long life. Refer to the "Set-Up" section of this manual.

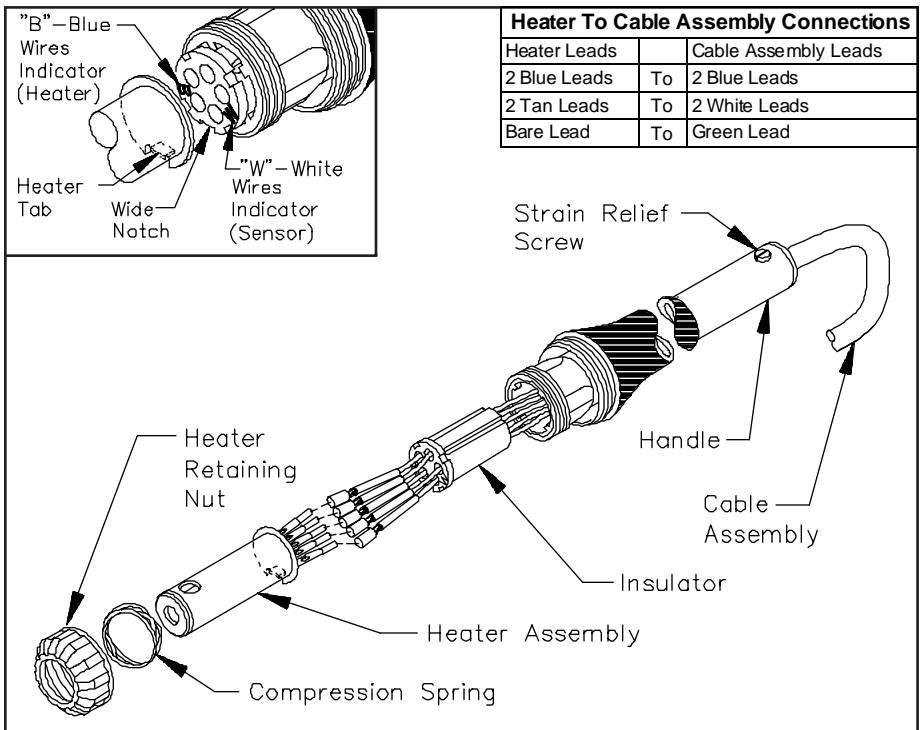

Replacement Parts

SP-1A/SP-2A Handpieces

Listed are the replacement parts which may be ordered through your local authorized PACE distributor. To obtain any other replacement parts, contact PACE Customer Service directly at Tel. #(301) 490-9860 or FAX #(301) 483-7030.

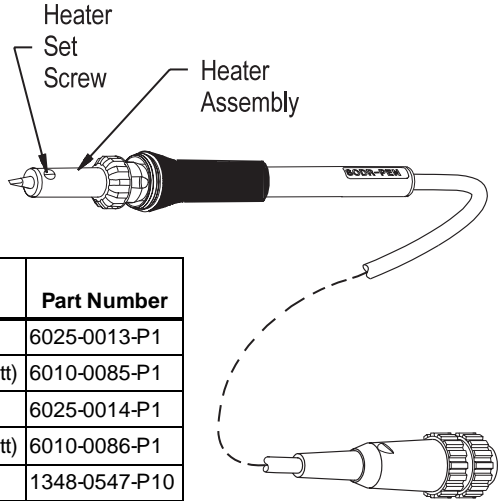

Item #	Description	Part Number
1	SP-1A Sodr-Pen Handpiece	6025-0013-P1
2	SP-1A Heater Assembly (37 Watt)	6010-0085-P1
3	SP-2A Sodr-Pen Handpiece	6025-0014-P1
4	SP-2A Heater Assembly (54 Watt)	6010-0086-P1
5	Heater Set Screw	1348-0547-P10

Table VI. SP-1A/SP-2A Parts

Accessory Items

Listed below is a packing list of the items shipped with the system plus optional and accessory items. This list is current at the time of publication of this manual.

ITEM NO.	DESCRIPTION	PART NUMBER	QTY. SUPPLIED	
			ST 40A	ST 40AE
<i>ACCESSORY TRAY ITEMS (PACKING LIST)</i>				
1	SP-2A Sodr-Pen (54 Watts)	6025-0014-P1	1	1
2	Power Supply Cord, 100 & 115 VAC	1332-0094	1	0
3	Power Supply Cord, 230 VAC	1332-0093	0	1
4	SP Tip & Tool Stand	6019-0043	1	1
5	Sponge for SP Tip & Tool Stand	4021-0008-P3	1	1
6	Wire Brush, 3/16 inch diameter	1127-0014-P5	1	1
7	Tip Tool	1100-0206	1	1
8	Rubber Foot		8	8
9	Screw, 8-32 x 1/2" Long		2	2
10	Thumb Nut, Knurled		2	2
<i>OPTIONAL & ACCESSORY ITEMS</i>				
11	Fuse, 1.0 Amp Time Lag (PPS 25A)	1159-0216		
	0.5 Amp Time Lag (PPS 25AE)	1159-0213		
	1.25 Amp Time Lag (PPS 25AJ)	1159-0217		
12	SP-1A Sodr-Pen (37 Watts)	6025-0013-P1		
13	Wire Brush, 1/8 inch diameter	1127-0006-P5		
14	AdapTip Kit (for SP-2A Sodr-Pen)	1360-0083-P1		
15	Tip & Temp. Selection System Booklet	5050-0251		
16	V-SX Vacuum Option (solder extraction)	6993-0131		
17	SX Tip & Tool Stand (for air handpieces)	6019-0044		
18	TT-65 ThermoTweez Handpiece	7025-0001-P1		
19	TT Tip & Tool Stand	6019-0046		
20	Tip Redi-Rak	6021-0007		
21	SMD Tip Accessory Kit	6993-0170		
22	Replacement Fiber Filler	1127-0013-P2		
23	Replacement Sponge Filler	4021-0006-P5		
24	Cord Retention System	6018-0090		

Table VII. Accessory Items

MANUAL IMPROVEMENT & COMMENT FORM

Instructions

1. Duplicate this form and submit comments on the copy. Keep the original to make future comments.
2. Complete all requested information.
3. Submit completed form to:

PACE Incorporated
Applications Engineering Fax: (301) 604-8782
9893 Brewers Court
Laurel, MD 20723-1990 U.S.A.

Document #	5050-0361	Rev. D	Date of Submission:
Nature of Change (Identify page and paragraph and include proposed rewrite, if possible.)			
Reason for Recommendation			
Name of Submitter:	Company or Organization:		
Mailing Address:	Telephone: ()		
	Voice:		
	Fax:		
	e-Mail:		

Thank you for your comments; they are greatly appreciated!